



CARL HANSEN & SØN

PASSIONATE CRAFTSMANSHIP



OUTDOOR ICONS

Chairs

Sunbeds

Tables

Sofas

Lounge Chairs



This publication is FSC® certified and printed in an environmentally friendly printhouse. Cover and interior pages are printed on Munken Lynx. The paper is produced in Sweden at one of the cleanest production facilities in the world using only half of the water that other paper factories use. The water is biologically cleaned and is so pure after the first purification, that it can be used as drinking water.



DESIGNED TO BRING US CLOSER TO NATURE

The three designers behind the Outdoor Icons collection never intended for their furniture to be merely admired from a distance. Instead, these handmade wooden pieces invite us to come close, to sit for hours with friends, to lounge, dine, drink, swing, and bathe in the sun. These are functional and flexible pieces meant to encourage authentic outdoor living: sunbeds that can easily be moved to catch the best light, tables and benches made for all-night garden parties, and comfortable lounge chairs designed to promote relaxation and inspire conversation. In short, this is modern design and quality craftsmanship working together to help bring us closer to nature and to one another during the best days of the year.

Inspiring Ideas, Timeless Designs



Morten Gøttler Cuba Chair Outdoor

Dedication to working with the best designers and the finest possible materials has always been fundamental to Carl Hansen & Søn, as has our commitment to honoring designers' original ideas.

The three inspiring designers included in the Outdoor Icons furniture collection – Bodil Kjær, Børge Mogensen, and Morten Gøttler – each bring their own unique vision and personality to outdoor furniture design. The essence of Børge Mogensen Outdoor is lightness, both in the colours featured in the collection, but also in the way the furniture can be used in so many ways, arranged and rearranged, and stored so easily. Bodil Kjær's Indoor-Outdoor series is an inspiring study in architectural harmony and elegance. Lastly, the iteration of Morten Gøttler's ingenious Cuba Chair proves that a truly timeless design will be at home in a variety of contexts, both in and out of doors.

What unites all three of these designers and their work, is the powerful idea that modern design can enhance the human experience by helping bring people and nature together in new, thoughtful, and inspiring ways.



Bodil Kjær Indoor-Outdoor



Børge Mogensen Outdoor Series

BØRGE MOGENSEN



OUTDOOR SERIES



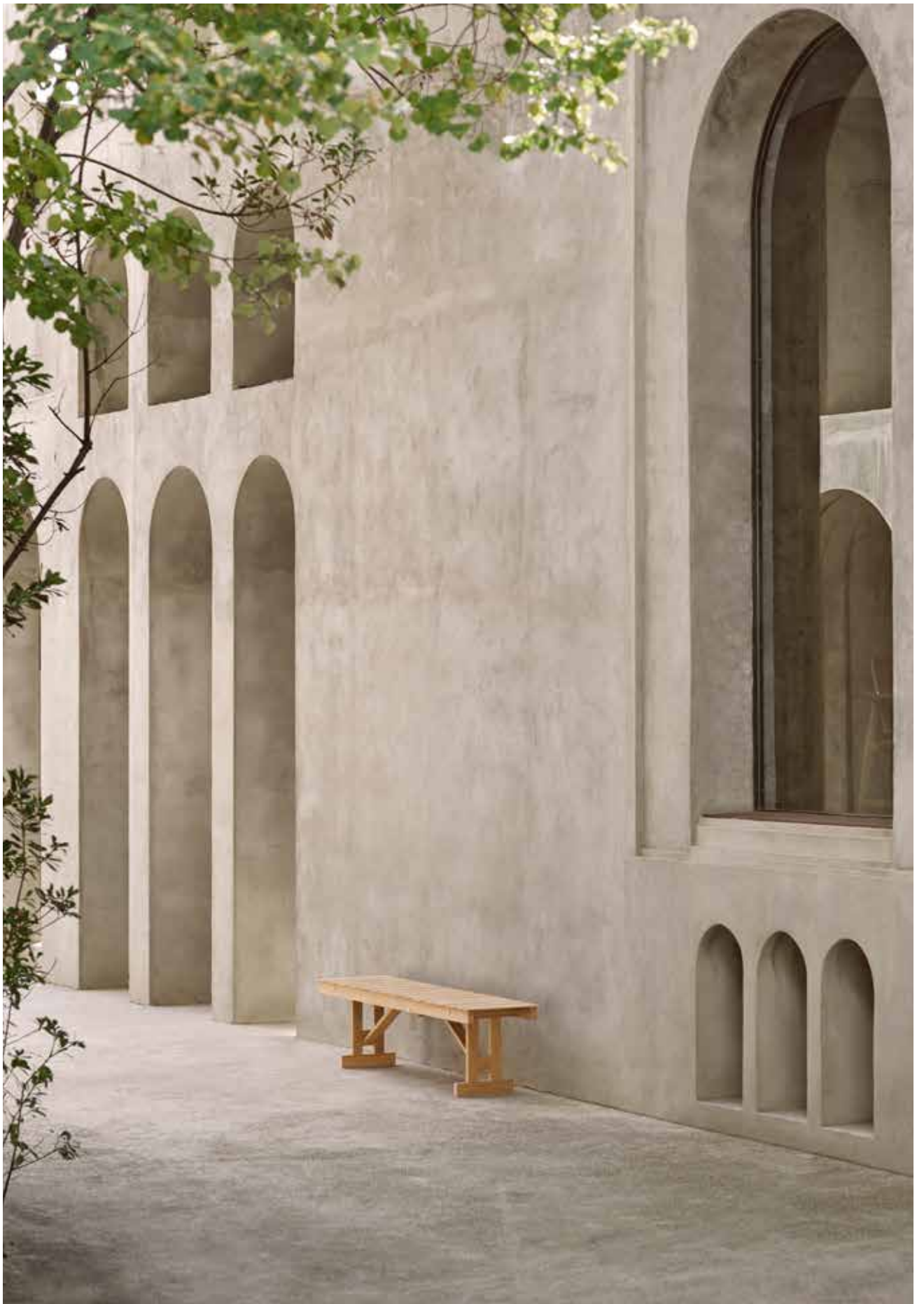

The Return of an Outdoor Icon

Originally developed in the late 1960's, Danish furniture designer Børge Mogensen's Outdoor Series was created as a lightweight, space-saving solution for the balcony of the designer's own home. When not in use, Mogensen's clever, utilitarian pieces could be folded up and stowed away or hung onto a wall as a decorative feature.

Like all of Børge Mogensen's furniture designs, the Outdoor Series combines functional strength with natural materials and a timeless aesthetic. Featuring a number of carefully crafted details that point to Mogensen's background as a cabinetmaker, the Outdoor Series features clear stylistic references to the American Shakers and to 19th Century English furniture design.

'This unique series is characterised by a clarity of design, by its straightforward but flexible functionality, and by a truly inviting feel,' explains Carl Hansen & Søn CEO Knud Erik Hansen, 'which is why we are extremely pleased that Carl Hansen & Søn can now re-introduce Børge Mogensen's Outdoor Series to a whole new generation.'

The Outdoor Series is made from solid, FSC®-certified teak. The series consists of a deck chair with cushion and footstool, a side table, a tray, a dining table with matching chairs, a table and bench set, and a matching wall mount. The cushion for the deck chair, the seat of the chair, and the footstool are upholstered with Sunbrella performance fabrics.

BM4570 DINING CHAIR
Seat: Heritage Papyrus 18006
Frame: Teak

BM3670 DINING TABLE
Table top: Teak
Base: Teak and stainless steel







BM4570 DINING CHAIR
Seat: Heritage Papyrus 18006
Frame: Teak

BM3670 DINING TABLE
Table Top: Teak
Base: Teak and stainless steel

BM1871 BENCH
Top and frame: Teak

BM1771 TABLE
Tabletop and frame: Teak

BM5768 FOOTSTOOL
Top: Heritage Papyrus 18006
Frame: Teak

BM1069 TRAY
Teak

BM5568 DECK CHAIR
Seat and frame: Teak
Cushion: Heritage Papyrus 18006



BM1871 BENCH
Top and frame: Teak

BM1771 TABLE
Tabletop and frame: Teak



BM1871 BENCH

Top and frame: Teak

Cushion: Heritage Papyrus 18006

BM1771 TABLE

Tabletop and frame: Teak

BM1069 TRAY
Teak

BM5768 FOOTSTOOL
Top: Heritage Papyrus 18006
Frame: Teak

BM5568 DECK CHAIR
Seat and frame: Teak
Cushion: Heritage Papyrus 18006





Known as 'the people's designer,' Børge Mogensen insisted on designing quality furniture that was within people's reach. With this guiding philosophy, he became a prominent figure of the Danish Design Movement.

Designer

Børge Mogensen

1914 – 1972

In line with the core concepts of Danish Design, Børge Mogensen's central ambition was to design simple and functional wooden furniture for private and public spaces. Throughout his life, Mogensen swore by the combination of solid wood (particularly oak, pine and beech) and leather, and, as a rule, his work avoids unnecessary adornments.

After completing his training as a cabinet maker in 1934, Mogensen studied furniture design at the Copenhagen School of Arts and Crafts and the Royal Academy of Fine Arts. As a student of Kaare Klint, Mogensen was inspired by Klint's straightforward approach. And while both men believed a successful design should always radiate calmness and functionalism, Mogensen's work placed considerable emphasis on furniture for informal interior spaces.

Later in life, Børge Mogensen taught design at the Royal Academy and participated in the annual Copenhagen Cabinetmakers' Guild furniture exhibitions. In 1948, along with his friend Hans J. Wegner, Mogensen entered the International Competition for Low-Cost Furniture at the Museum of Modern Art in New York. Just before his death in 1972, Mogensen was appointed Honorary Royal Designer for Industry at the Royal Society of Arts in London.

MATERIALS

Frame: Solid wood.

Seat/Cushion: Foam with Sunbrella fabric in Heritage Papyrus 18006.

Fittings: Stainless steel.

UNTREATED

TEAK

•



Untreated Teak

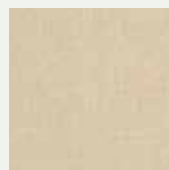

Sunbrella fabric in
Heritage Papyrus 18006

FSC® C135991

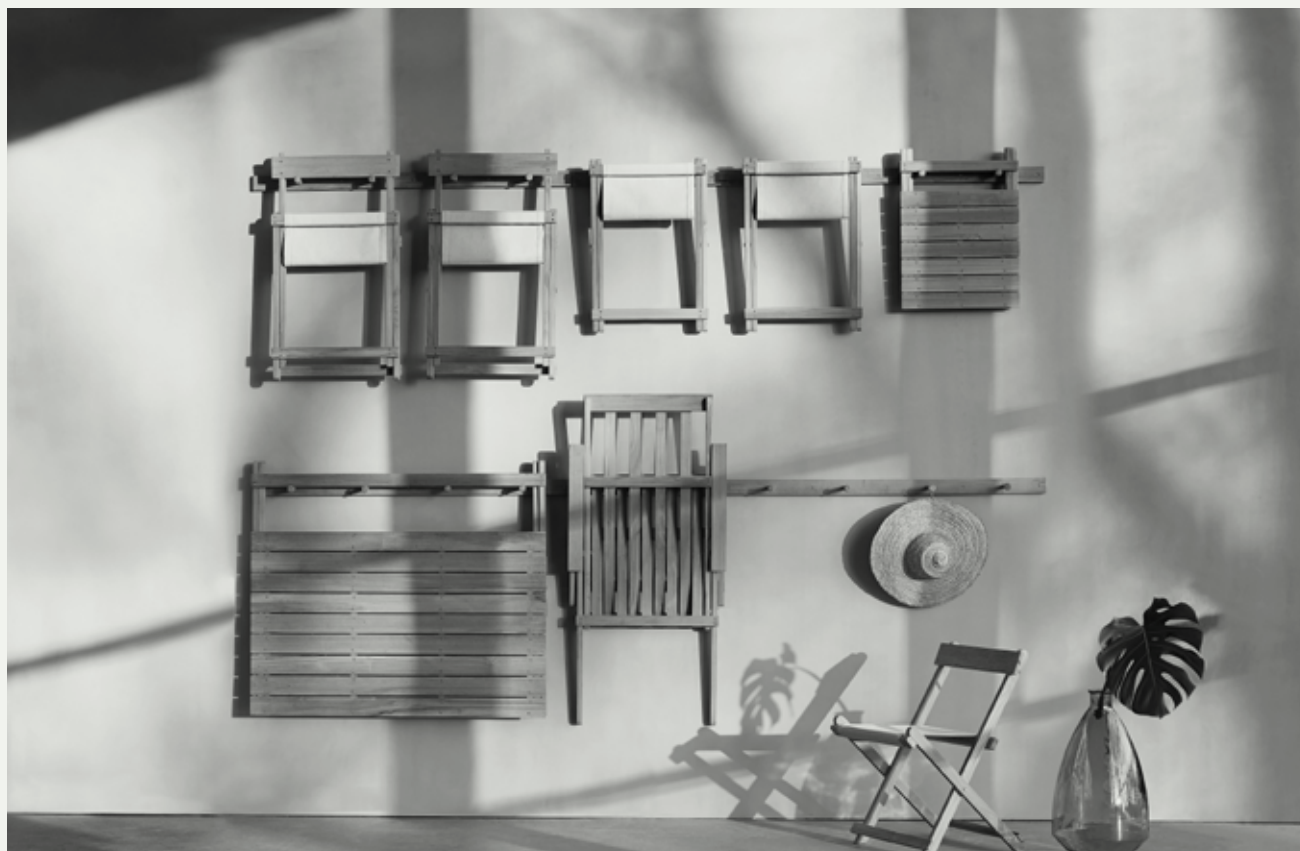

Pieces from the Børge Mogensen Outdoor collection mounted on the BM52705 Wall Mounts originally designed between 1968-70.

BM5568 DECK CHAIR
 Teak
 Incl. cushion
 Cushion is sold separately

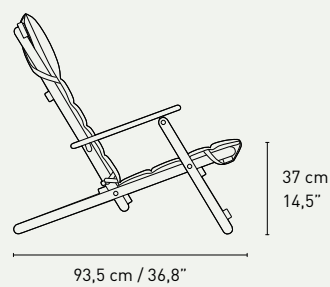
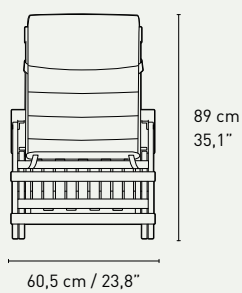

OUTDOOR SERIES

BM5868 SIDE TABLE
Teak

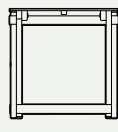

45 cm / 17,7"

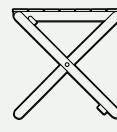

45 cm / 17,7"

45 cm
17,7"

BM5768 FOOTSTOOL
Teak and Heritage Papyrus 18006

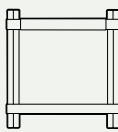

45 cm / 17,7"

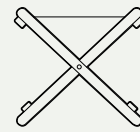

51,5 cm / 20,3"

47 cm
18,4"

BM1069 TRAY
Tray fits BM5768 Footstool
Teak



58 cm / 22,9"

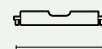

34,5 cm / 13,6"

5 cm
2"

BM4570 DINING CHAIR
Teak and Heritage Papyrus 18006

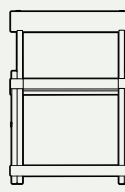

50 cm / 19,7"

72 cm
28,3"

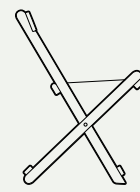

53 cm / 20,9"

43,5 cm
17,2"

BM3670 DINING TABLE
4 seats
Teak and Stainless steel

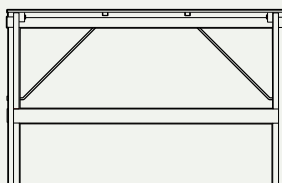

115 cm / 45,3"

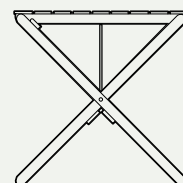

71,5 cm / 28,1"

72 cm
28,3"

BM1771 TABLE
6-8 seats
Teak

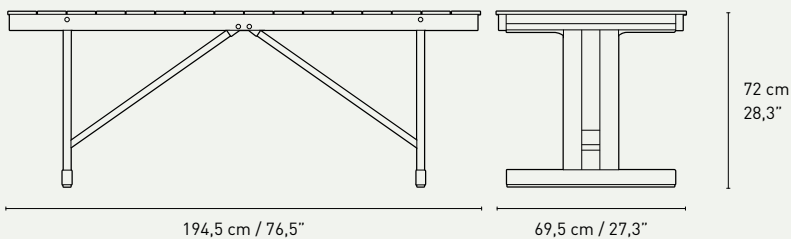

BM1871 BENCH
Teak

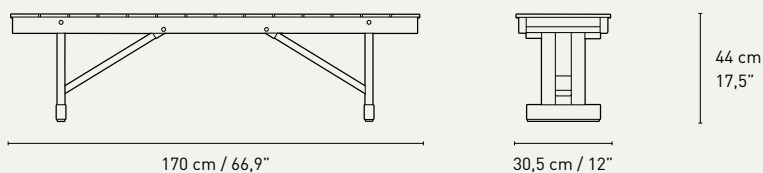

BM1871 CUSHION
Heritage Papyrus 18006



BM52705S WALL MOUNT
Teak

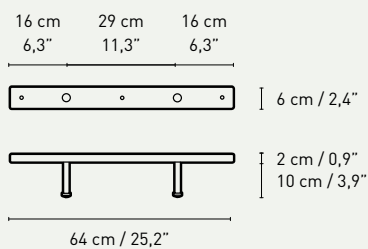

BM52705L WALL MOUNT
Teak

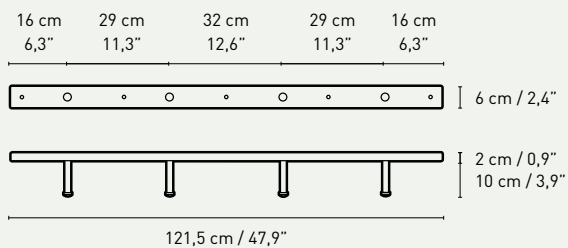

BODIL KJÆR



INDOOR-OUTDOOR





Elegant Versatility for Every Season

Inspired by the bold geometries of Cubism and guided by the principles of human scale and aesthetic balance, architect Bodil Kjær's iconic Indoor-Outdoor series was conceived as a collection of harmonious, contemporary architectural elements that would relate to their immediate surroundings, whether in or out of doors.

Six decades after the initial launch of Kjær's Indoor-Outdoor collection, Carl Hansen & Søn have now added this timeless series to its collection of design classics. Today, the collection is being produced for the first time in solid, FSC®-certified teak, a durable wood species which can withstand a wide range of weather conditions and will develop a beautiful patina over time.

'Indoor-Outdoor was designed for modernist spaces and for weather conditions that are very similar to those in Denmark,' explains Carl Hansen & Søn CEO Knud Erik Hansen, 'at the same time, these pieces bring together the best of Scandinavian and international design traditions. The furniture has a clear identity, an evident simplicity, and is based on high-quality materials and superior craftsmanship. For all these reasons, it makes very good sense to add Bodil Kjær's sophisticated furniture series to our collection.'

The Indoor-Outdoor series comprises of a lounge chair, a small table, a dining table, a dining chair, a two-seater bench, a swing seat, and a sunbed. All seats, chairs, and beds can be supplied with slender cushions made from weather-resistant Sunbrella fabric.

BK15 DINING TABLE
Tabletop and frame: Teak, oil

BK10 DINING CHAIR
Body and frame: Teak, oil
Cushion: Canvas 5453





BK16 SIDE TABLE
Tabletop and frame: Teak, oil

BK12 LOUNGE SOFA
Body and frame: Teak, oil
Cushion: Canvas 5453

BK10 DINING CHAIR
Body and frame: Teak, oil
Cushion: Canvas 5453



BK10 DINING CHAIR
Body and frame: Teak, oil
Cushion: Canvas 5453

BK16 SIDE TABLE
Tabletop and frame: Teak, oil

BK14 SUNBED
Seat/back and frame: Teak, oil

BK11 LOUNGE CHAIR
Body and frame: Teak, oil
Cushion: Canvas 5453

BK10 DINING CHAIR
Body and frame: Teak, oil

BK15 DINING TABLE
Tabletop and frame: Teak, oil

BK12 LOUNGE SOFA
Body and frame: Teak, oil

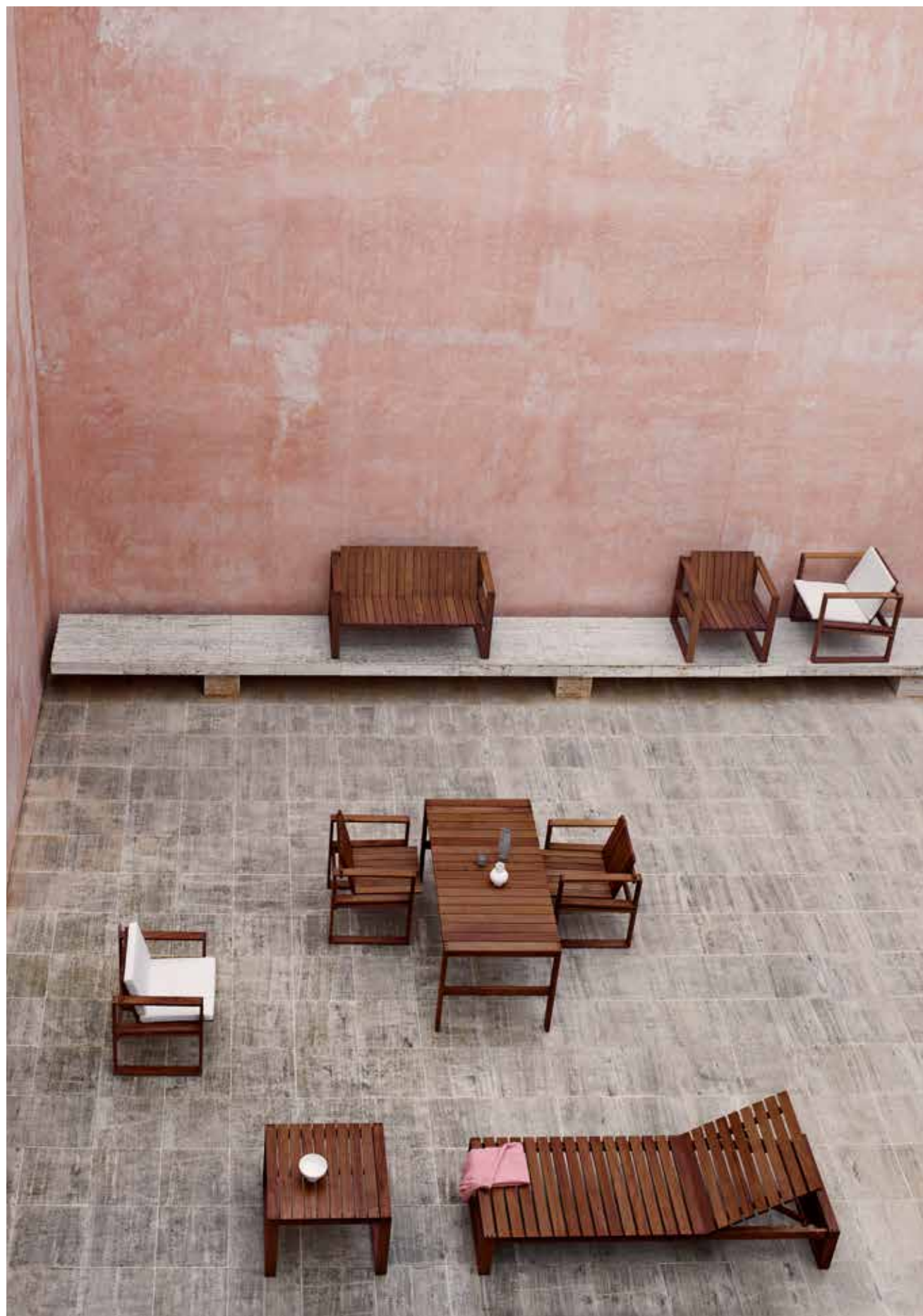



BK14 SUNBED
Seat/back and frame: Teak, oil
Cushion: Canvas 5453

BK16 SIDE TABLE
Tabletop and frame: Teak, oil

BK13 SWING SOFA
Body and frame: Teak, oil
Cushion: Canvas 5453





Designer

Bodil Kjær

Born 1932

Bodil Kjær grew up on her family's ancestral farm near Horsens, Denmark, a home shaped by an appreciation of quality and aesthetics, a respect for nature, and an interest in societal dynamics. After completing her schooling, she spent a year in the UK where she became interested in furniture and design. Upon return, Kjær took up interior design studies under the tutelage of prominent figures such as Finn Juhl and Jørgen Ditzel.

Having honed her design skills in the US via the American Scandinavian Foundation, Kjær created several furniture pieces, or architectural elements, as she prefers to call them. She has always been preoccupied with how to construct furniture from a purely technical perspective – from the inside out, rather than based on form.

In 1960, Kjær established her studio in Copenhagen, creating showrooms, offices and exhibitions. Five years later she moved to London for further studies at the Royal College of Art and the Architectural Association School of Architecture. She remained there until 1979, working as a senior architect at the engineering company, Arup, on office, factory and university building projects. Kjær has been a guest lecturer and visiting professor at many leading architecture schools in Denmark, the UK and the US. Today she lives in the East Jutland region of Denmark.

Throughout her career as a professor and architect, Bodil Kjær traveled the world to gather knowledge and communicate her considerable insight into the relationship between design and architecture. The main goal of her travels was to explore methods and materials that could be used to realize her ideas for functional furniture systems and work environments.

MATERIALS

Frame: Solid wood

Seat/Cushion: Foam with Sunbrella fabric in canvas 5453

	OIL
TEAK	•



Oiled Teak

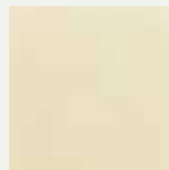

Sunbrella fabric in Canvas 5453

FSC® C135991

Detail from the Indoor-Outdoor furniture series,
designed by Bodil Kjær in 1959.



BK10 DINING CHAIR
Oiled teak

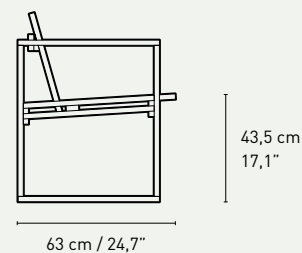
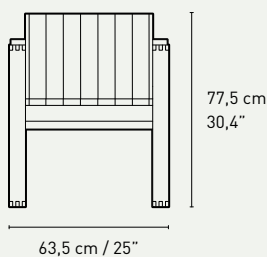

BK10 CUSHION
Sunbrella Canvas 5453

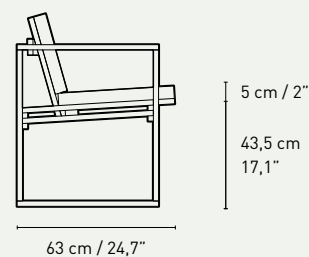
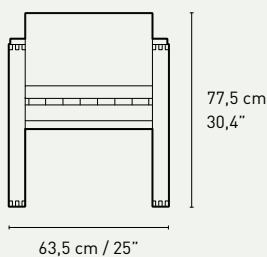

BK15 DINING TABLE
4 seats
Oiled teak

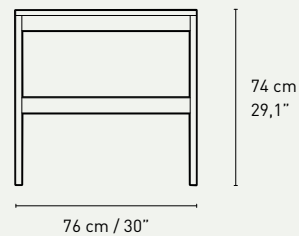
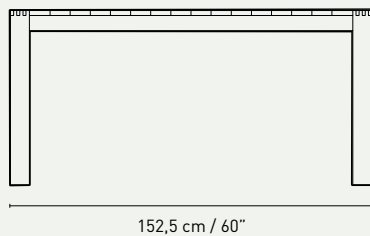
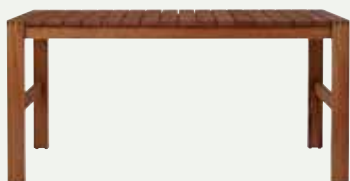

INDOOR-OUTDOOR SERIES

BK12 LOUNGE SOFA
Oiled teak

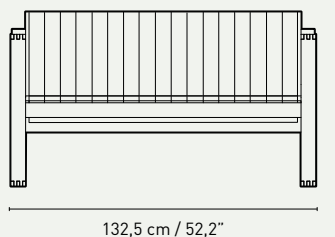
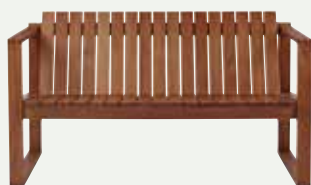

74,5 cm
29,3"

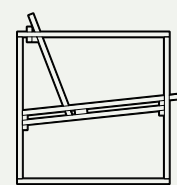

39,5 cm
15,6"

72,5 cm / 28,5"

BK12 CUSHION
Sunbrella Canvas 5453

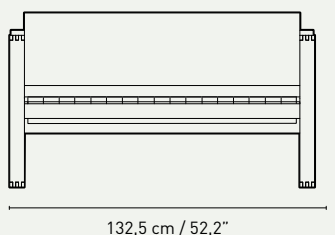

76 cm
29,9"

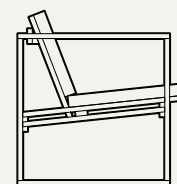

5 cm / 2"

44,5 cm
17,5"

72,5 cm / 28,5"

BK11 LOUNGE CHAIR
Oiled teak

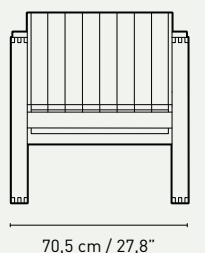

74,5 cm
29,3"

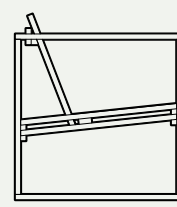

40 cm
15,7"

72,5 cm / 28,5"

BK11 CUSHION
Sunbrella Canvas 5453

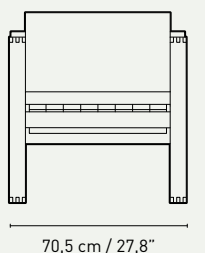

76 cm
29,9"

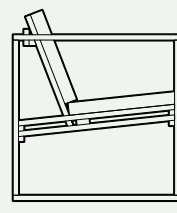

5 cm / 2"

45 cm
17,1"

72,5 cm / 28,5"

BK16 SIDE TABLE
Oiled teak

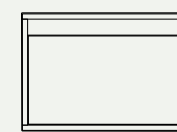
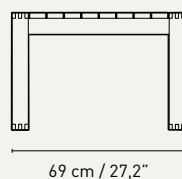

47 cm
18,5"

66 cm / 26"

BK14 SUNBED
Oiled teak

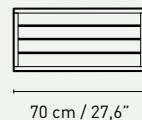
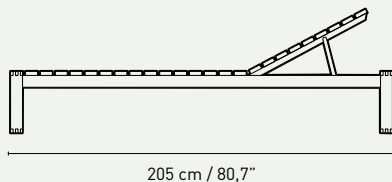

33,5 cm
13,2"

BK14 CUSHION
Sunbrella Canvas 5453

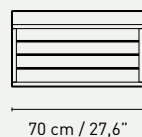
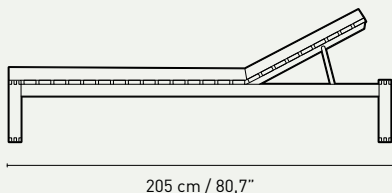

5 cm / 2"
38,5 cm
15,2"

BK13 SWING SOFA
Oiled teak

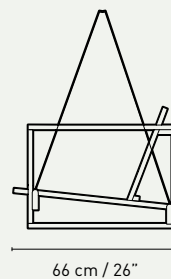
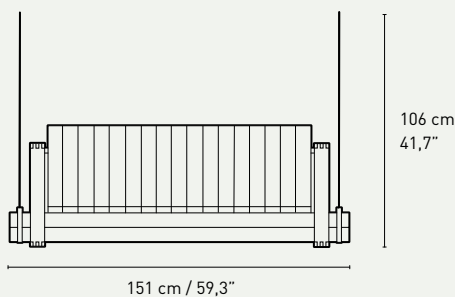
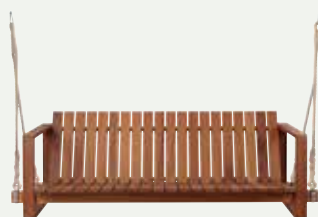

BK13 CUSHION
Sunbrella Canvas 5453



BK17 A FRAME
Oiled teak

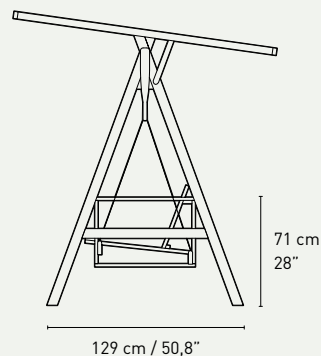
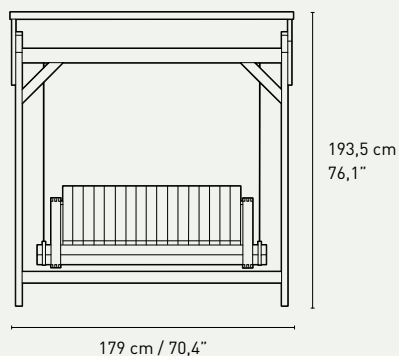

MORTEN GØTTLER



CUBA CHAIR OUTDOOR



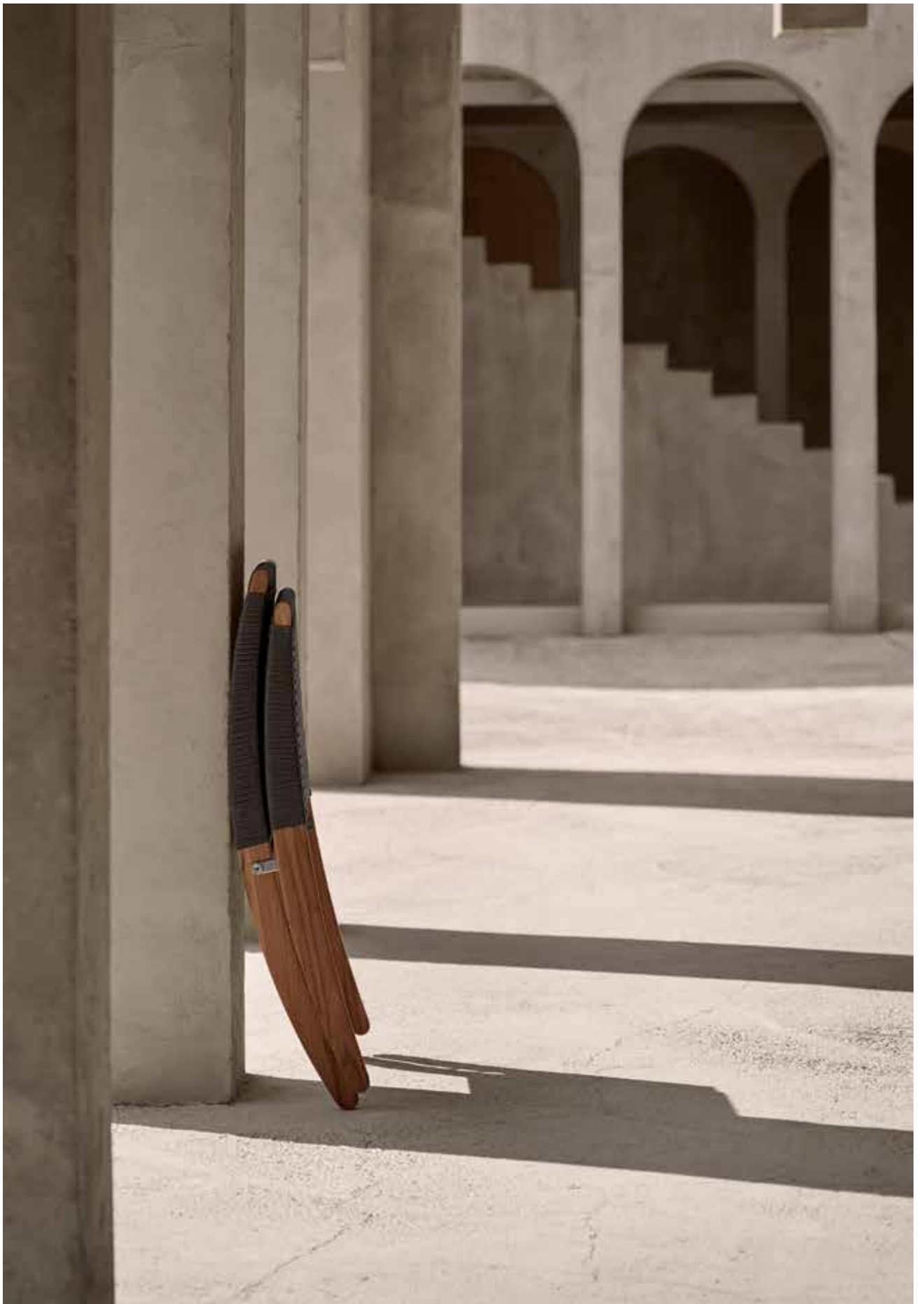

A New Classic Ventures Outside

Designed in 1997, Morten Gøttler's ingenious Cuba Chair is an excellent example of the designer's focused approach to furniture design. With its low, open construction, the Cuba Chair encourages an informal sitting position and clearly reflects the democratic ideals of modernist design. In just a few decades, the deceptively simple Cuba Chair has become a new classic of Danish furniture design.

Now, for the first time, this lightweight and highly functional folding chair is available in a weather-resistant variant ideal for the patio, terrace, balcony, and garden spaces. While the aesthetic and functional features of this new Cuba Chair are identical to the original, the materials have been updated for outdoor use.

'The Cuba Chair has always offered exquisite comfort,' says Knud Erik Hansen, CEO of Carl Hansen & Søn, 'and the aesthetic and functional qualities of this design are such that it makes perfect sense to supplement the current collection with a new, outdoor version that features exclusive materials that are just as suitable indoors as they are outside.'

The new outdoor Cuba Chair is made from solid, FSC®-certified teak, water and light-resistant flat-weave rope, and stainless steel fittings that guarantee long-term durability and resistance to wind and weather.



Designer

Morten Gøttler

Born 1944

Striking the perfect balance between form and function is the starting point for Danish architect and self-taught furniture designer Morten Gøttler's design process, in which he acknowledges his Scandinavian roots through his simple and readable forms, high-quality craftsmanship and long-lasting materials. Gøttler says he is indebted to the legendary furniture designers who set the standard in the 1950s and 1960s, the golden age of Danish design.

After working with product development and design for a number of companies, Gøttler opened his own design studio in 1972. He has since worked in a wide range of genres, including domestic art, packaging, toys, graphics and lighting for Danish and international companies. In 1984, Gøttler decided to focus primarily on furniture design, using an approach rooted in the modern Scandinavian design tradition and the firm belief that innovation is the foundation for successful design.

Gøttler's clean, easy aesthetic is characterized by carefully considered form, exquisite comfort, and close attention to detail – all brought to life using high-quality materials.

Born in Copenhagen, Morten Gøttler became a self-taught designer and architect recognized for his exceptional understanding of wood. His passion for furniture made him focus primarily on furniture design from 1984, taking his inspiration from the modern Scandinavian design tradition.

MATERIALS

Frame: Oiled teak
 Seat and back: Grey flat-weave rope
 Fittings: Stainless steel

	OIL
TEAK	•



Oiled teak

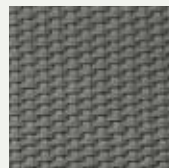

Grey flat-weave rope

FSC® C135991



Detail of the new outdoor Cuba Chair, designed by Morten Gøttler in 1997.

MG501 CUBA CHAIR OUTDOOR
Oiled teak and Grey flat-weave rope

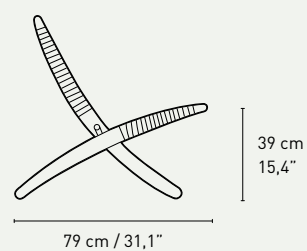
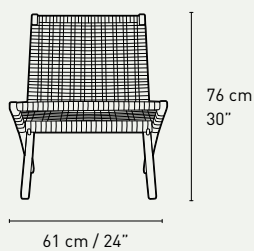



Detail of the solid, FSC®-certified teak used in crafting Kjær's Indoor-Outdoor furniture collection.

The Heart of The Outdoor Collection

Proper material selection is the key to crafting furniture pieces that not only resist the elements, but that will also age gracefully with time. This is why Carl Hansen & Søn's Outdoor Furniture features only the highest quality materials, including Sunbrella performance fabrics, rust free fittings, and flat-weave rope that can handle harsh and ever-changing weather conditions. And, at the heart of this unique collection, is the solid, FSC®-certified teak used to craft all of our Outdoor Furniture.

Teak (*Tectona grandis*) is a tropical hardwood, prized for its durability and rich aesthetic qualities. Native to south and southeast Asia, teak has been commercially cultivated throughout the tropics since the middle of the 19th century. Teak's tight wood grain, high oil content, and high tensile strength make it naturally resistant to fungi, pests, rot, and moisture damage. This inherent durability, along with teak's warm spectrum of colours and its technical versatility, make it ideal for use in boat building, exterior architecture, and outdoor furniture design.

Since 2017, all of the solid, FSC®-certified teak used in Carl Hansen & Søn's Outdoor Furniture Collection has been responsibly sourced and milled in Vietnam, where teak was first introduced in 1952.

To learn more about furniture maintenance and how to care for teak, visit www.carlhansen.com.

Crafting Modern Design for Over a Century

At Carl Hansen & Søn, we believe that iconic design is a combination of simplicity, aesthetics, and functionality brought to life through skilful work with the highest quality materials. For over 100 years, we have specialized in providing the outstanding furniture craftsmanship that brings visionary design concepts to life.

Since 1908, the company's success has depended on two core ideas: an uncompromising commitment to the finest craftsmanship and alliances with exceptional designers who continually reinvent and refine the concept of modern design. Through the years, Carl Hansen & Søn has maintained a strong focus on preserving Danish design classics while continuing to expand our collection to represent influential new designers. Our goal: to gather the best, most iconic modern furniture designs under one roof.

We produce important works by the renowned mid-century Danish masters Hans J. Wegner, Arne Jacobsen, Kaare Klint, and many others, working closely with their families and studios to ensure absolute adherence to their visions. We also partner with contemporary designers who uphold the core Danish Modern principles of simplicity, functionality, and craftsmanship while breathing new life into modern spaces.



Danish architect Bodil Kjær with the original drawings for her Indoor-Outdoor furniture series.



For more than 100 years, Carl Hansen & Søn has specialized in providing the outstanding furniture craftsmanship that brings visionary design concepts to life.



A craftsman in the Carl Hansen & Søn workshop, at work on the CH23 dining chair, designed by Hans J. Wegner in 1950.

